

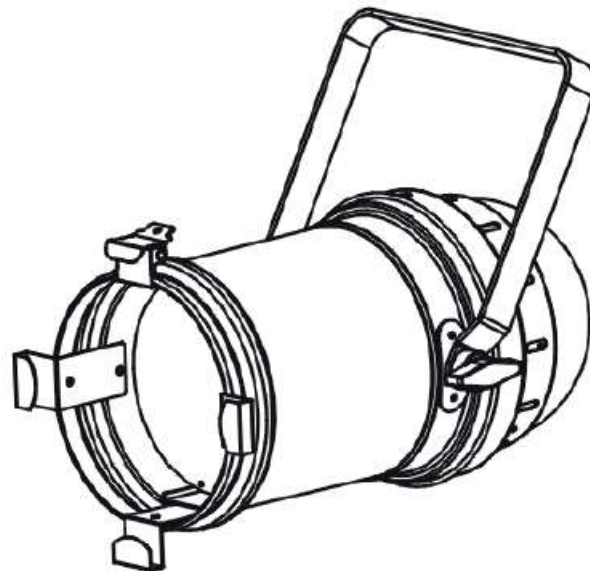

## PAR Z100 5K



## User Instructions

A.D.J. Supply Europe B.V.  
Junostraat 2  
6468 EW Kerkrade  
The Netherlands  
[www.adj.eu](http://www.adj.eu)

©2018 ADJ Products, LLC all rights reserved. Information, specifications, diagrams, images, and instructions herein are subject to change without notice. ADJ Products, LLC logo and identifying product names and numbers herein are trademarks of ADJ Products, LLC. Copyright protection claimed includes all forms and matters of copyrightable materials and information now allowed by statutory or judicial law or hereinafter granted. Product names used in this document may be trademarks or registered trademarks of their respective companies and are hereby acknowledged. All non-ADJ Products, LLC brands and product names are trademarks or registered trademarks of their respective companies.

**ADJ Products, LLC** and all affiliated companies hereby disclaim any and all liabilities for property, equipment, building, and electrical damages, injuries to any persons, and direct or indirect economic loss associated with the use or reliance of any information contained within this document, and/or as a result of the improper, unsafe, insufficient and negligent assembly, installation, rigging, and operation of this product.

#### DOCUMENT VERSION

Please check [www.adj.com](http://www.adj.com) for the latest revision/update of this guide.

Date	Document Version	Software Version ≥	DMX Channel Mode	Notes
09/27/17	1	1.0	1/2/3	Initial Release
01/02/18	2	1.2	1/2/3/4	Added: RDM Protocol Support, 4 CH DMX Mode, Stage 2 Dimmer Curve, & Default Settings System Menu

Europe Energy Saving Notice

Energy Saving Matters (EuP 2009/125/EC)

Saving electric energy is a key to help protecting the environment. Please turn off all electrical products when they are not in use. To avoid power consumption in idle mode, disconnect all electrical equipment from power when not in use. Thank you!

## Contents

GENERAL INFORMATION .....	4
GENERAL INSTRUCTIONS .....	4
FEATURES.....	4
HANDLING PRECAUTIONS.....	4
SAFETY PRECAUTIONS .....	5
DMX SET UP .....	6
SYSTEM MENU .....	8
DMX OPERATION .....	11
BEAM ANGLE ADJUSTMENT .....	11
1 CHANNEL MODE .....	12
2 CHANNEL MODE .....	12
3 CHANNEL MODE .....	12
4 CHANNEL MODE .....	12
DIMMER CURVE CHART .....	13
DIMENSIONAL DRAWINGS.....	13
INSTALLATION.....	14
MULTIPLE UNIT POWER LINKING .....	14
FUSE REPLACEMENT .....	14
CLEANING.....	14
TROUBLE SHOOTING.....	14
SPECIFICATIONS .....	15
ROHS - A great Contribution to the Conservation of Environment .....	16
WEEE – Waste of Electrical and Electronic Equipment .....	17
NOTES .....	18
NOTES .....	<b>Fehler! Textmarke nicht definiert.</b>

## GENERAL INFORMATION

**Unpacking:** Thank you for purchasing the Par Z100 5K by ADJ Products, LLC. Every Par Z100 5K has been thoroughly tested and has been shipped in perfect operating condition. Carefully check the shipping carton for damage that may have occurred during shipping. If the carton appears to be damaged, carefully inspect your fixture for any damage and be sure all equipment necessary to operate the unit has arrived intact. In the event damage has been found or parts are missing, please contact our toll free customer support number for further instructions. Please do not return this unit to your dealer without contacting customer support first.

**Introduction:** The Par Z100 5K is a DMX intelligent, zooming, LED par fixture. The Par Z100 5K also operates as a stand alone fixture. This fixture is suitable for theaters, studios, retail stores, and other similar locations. *For best results use fog or special effects smoke to enhance the beams projections.*

**Customer Support:** If you encounter any problems, please contact your trusted American Audio shop. We also offer the possibility, to contact us directly: You can contact us via our website [www.adj.eu](http://www.adj.eu) or via email: [support@adj.eu](mailto:support@adj.eu)

**Warning!** To prevent or reduce the risk of electrical shock or fire, do not expose this unit to rain or moisture.

**Warning!** *This may cause severe eye damage. Avoid looking directly into the light source at all times!*

## GENERAL INSTRUCTIONS

To optimize the performance of this product, please read these operating instructions carefully to familiarize yourself with the basic operations of this unit. These instructions contain important safety information regarding the use and maintenance of this unit. Please keep this manual with the unit, for future reference.

## FEATURES

- DMX-512 Protocol Compatible (4 DMX Channel Modes: 1 Channel, 2 Channels, 3 Channels, & 4 Channels)
- 5-Pin XLR In/Out Connections
- powerCON In/Out Connections
- 6 Dimmer Curve Modes
- Digital Display for Address and Function Setting
- Gamma Correction Adjustment
- Dimming Frequency Adjustment
- Multiple Unit Power Linking (See page 14)

## HANDLING PRECAUTIONS

**Caution!** There are no user serviceable parts inside this unit. Do not attempt any repairs yourself, doing so will void your manufactures warranty. In the unlikely event your unit may require service please contact ADJ Products, LLC.

*During operation the housing may become extremely hot. Avoid touching the unit with bare hands while in use.*

*ADJ Products, LLC will not accept any liability for any resulting damages caused by the non-observance of this manual or any unauthorized modification to this unit.*

## **SAFETY PRECAUTIONS**

***For Your Own Personal Safety, Please Read and Understand This Manual Completely Before You Attempt To Install Or Operate This Unit!***

- To reduce the risk of electrical shock or fire, do not expose this unit rain or moisture
- Do not spill water or other liquids into or on to your unit.
- Be sure that the local power outlet match that of the required voltage for your unit.
- Do not attempt to operate this unit if the power cord has been frayed or broken.
- Do not attempt to remove or break off the ground prong from the electrical cord. This prong is used to reduce the risk of electrical shock and fire in case of an internal short.
- Disconnect from main power before making any type of connection.
- Do not remove the cover under any conditions. There are no user serviceable parts inside.
- Never operate this unit when it's cover is removed.
- Always be sure to mount this unit in an area that will allow proper ventilation. Allow about 6" (15cm) between this device and a wall.
- Do not attempt to operate this unit, if it becomes damaged.
- This unit is intended for indoor use only, use of this product outdoors voids all warranties.
- Always mount this unit in safe and stable matter.
- Power-supply cords should be routed so that they are not likely to be walked on or pinched by items placed upon or against them, paying particular attention to cords at plugs, convenience receptacles, and the point where they exit from the appliance.
- Cleaning -The fixture should be cleaned only as recommended by the manufacturer. See page 14 for cleaning details.
- Heat -This fixture should be situated away from heat sources such as radiators, heat registers, stoves, or other appliances (including amplifiers) that produce heat.
- The fixture should be serviced by qualified service personnel when:
  - A. Objects have fallen, or liquid has been spilled into the appliance.
  - B. The appliance has been exposed to rain or water.
  - C. The appliance does not appear to operate normally or exhibits a marked change in performance.

## DMX SET UP

**Power Supply:** The ADJ Par Z100 5K contains an automatic voltage switch, which will auto sense the voltage when it is plugged into the power source. With this switch there is no need to worry about the correct power voltage, this unit can be plugged in anywhere.

**DMX-512:** DMX is short for Digital Multiplex. This is a universal protocol used by most lighting and controller manufactures as a form of communication between intelligent fixtures and controllers. A DMX controller sends DMX data instructions from the controller to the fixture. DMX data is sent as serial data that travels from fixture to fixture via the DATA "IN" and DATA "OUT" XLR terminals located on all DMX fixtures (most controllers only have a DATA "OUT" terminal).

**DMX Linking:** DMX is a language allowing all makes and models of different manufactures to be linked together and operate from a single controller, as long as all fixtures and the controller are DMX compliant. To ensure proper DMX data transmission, when using several DMX fixtures try to use the shortest cable path possible. The order in which fixtures are connected in a DMX line does not influence the DMX addressing. For example; a fixture assigned a DMX address of 1 may be placed anywhere in a DMX line, at the beginning, at the end, or anywhere in the middle. Therefore, the first fixture controlled by the controller could be the last fixture in the chain. When a fixture is assigned a DMX address of 1, the DMX controller knows to send DATA assigned to address 1 to that unit, no matter where it is located in the DMX chain.

**Data Cable (DMX Cable) Requirements (For DMX and Master/Slave Operation):** The Par Z100 5K can be controlled via DMX-512 protocol. The Par Z100 5K has four DMX channel modes; 1 channel mode, 2 channel mode, 3 channel mode, & 4 channel mode. The DMX address is set electronically using the controls on the rear panel of the unit. Your unit and your DMX controller require an approved DMX-512 110 Ohm Data cable for data input and data output (Figure 1). We recommend Accu-Cable DMX cables. If you are making your own cables, be sure to use standard 110-120 Ohm shielded cable (This cable may be purchased at almost all professional sound and lighting stores). Your cables should be made with a male and female XLR connector on either end of the cable. Also remember that DMX cable must be daisy chained and cannot be split.



Figure 1

**Notice:** Be sure to follow figures two and three when making your own cables. Do not use the ground lug on the XLR connector. Do not connect the cable's shield conductor to the ground lug or allow the shield conductor to come in contact with the XLR's outer casing. Grounding the shield could cause a short circuit and erratic behavior.

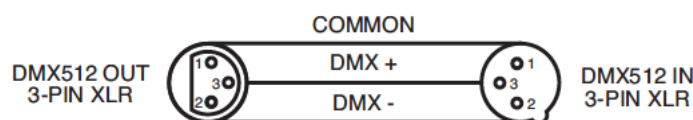

Figure 2

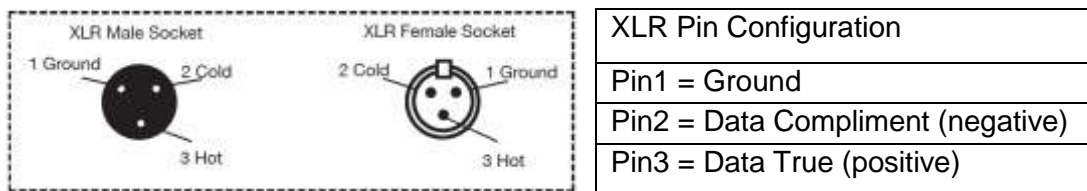

Figure 3

**Special Note: Line Termination.** When longer runs of cable are used, you may need to use a terminator on the last unit to avoid erratic behavior. A terminator is a 110-120 ohm 1/4 watt resistor which is connected between pins 2 and 3 of a male XLR connector (DATA + and DATA -). This unit is inserted in the female XLR connector of the last unit in your daisy chain to terminate the line. Using a cable terminator (ADJ part number Z-DMX/T) will decrease the possibilities of erratic behavior.



Termination reduces signal errors and avoids signal transmission problems and interference. It is always advisable to connect a DMX terminal, (Resistance 120 Ohm 1/4 W) between PIN 2 (DMX-) and PIN 3 (DMX +) of the last fixture.

Figure 4

**5-Pin XLR DMX Connectors.** This unit use 5-pin DMX-512 data cables for DATA transmission. 5-pin DMX fixtures may be implemented in a 3-pin DMX line. When inserting standard 5-pin data cables in to a 3-pin line a cable adaptor must be used, these adaptors are readily available at most electric stores. The chart below details a proper cable conversion.

<b>3-Pin XLR to 5-Pin XLR Conversion</b>		
Conductor	3-pin XLR Female (Out)	5-pin XLR Male (In)
Ground/Shield	Pin 1	Pin 1
Data compliment (- signal)	Pin 2	Pin 2
Data True (+ signal)	Pin 3	Pin 3
Not used		Pin 4 - Do Not Use
Not used		Pin 5 - Do Not Use

Menu

- Addr - (001 - 512) DMX 512 Address
- chMd - [ 1Ch  
2Ch  
3Ch  
4Ch ] Channel Mode
- dmSt - [ HoLd  
bLNd ] DMX State
- diMd - [ StdA  
St91  
tU  
ArAL  
tHAl  
St92 ] Dimmer Mode
- FRFq - [ 900 ••• 1500 / 2500 / 4000  
5000 / 10H / 15H / 20H / 25H ] Dimming frequency
- gAmn - [ 2.0  
2.2  
2.4  
2.8 ] Gamma correction
- diSP - dS IP Display inversion
- nAmD - [ d000 - d255  
5000 - 5255 ] Manual mode
- tEst Test
- tENP Temperature
- FhrS Fixture Hours
- vEr Software Version
- dFSE - [ on  
off ] Restore factory settings



**System Menu: When making adjustments press ENTER to confirm your setup then press and hold the MENU button for at least 3 seconds. To exit without making any adjustments press the MENU button. The display will lock after 30 seconds, press the MENU button for 3 seconds to unlock.**

**Addr** - DMX Address Setting.

1. Press the either the MENU, UP, or DOWN buttons until **Addr** is displayed, press ENTER.
2. The current address will now be displayed and flashing. Press the UP or DOWN buttons to find your desired address. Press ENTER to set your desired DMX address.

**ChNd** - This will let select your desired DMX channel mode.

1. Press the either the MENU button until **ChNd** is displayed, press ENTER. The current DMX channel mode will be displayed.
2. Press the UP or DOWN buttons to find your desired DMX channel mode and press ENTER to confirm and exit.

**dnst** - This mode can be used as a precaution mode, that in case the DMX signal is lost, interrupted, or power is lost, the operating mode chosen in the setup is the running mode the fixture will go into when the DMX signal is lost. You can also set this as the operating mode you would like the unit to return to when power is applied.

1. Press the MENU button until **dnst** is displayed, and either “**BLND**” or “**HOLD**” will be displayed beneath.
2. Press ENTER and the bottom choice will begin to flash. Use the UP or DOWN buttons to choose an operating mode you would like the unit to start up in when power is applied or the DMX signal is lost.
  - BLND** (Blackout) - If the DMX signal is lost or interrupted, the unit will automatically go into stand by mode.
  - HOLD** - If the DMX signal is lost the fixture will stay in the last DMX setting. If power is applied and this mode is set, the unit will automatically go into the last DMX set up.
3. Press ENTER to confirm your desired set up.

**diNd** - This will let select your desired dimmer curve.

1. Press the MENU button until **diNd** is displayed, and press ENTER. 1 of 6 dimmer curves will be displayed. “**STDA**” (standard), “**STGE**” (stage), “**TV**” (TV), “**ARAL**” (Architectural), “**THAL**” (Theatre), or (Stage 2). See the dimmer curve chart on page 13 for more info.
2. Press the UP or DOWN buttons to find your desired dimmer curve and press ENTER to confirm and exit.

**FA29** - With this function you can adjust the dimming frequency.

1. Press the MENU button until **FA29** is displayed, press ENTER.
2. Use the UP or DOWN buttons to adjust the dimming frequency between 900hz, 1000hz, 1100hz, 1200hz, 1300hz,1400hz, 1500hz, 2500hz, 4000hz, 5000hz, 10000hz, 15000hz,20000hz, or 250000hz.
3. Once you have found your desired dimming frequency press ENTER to confirm.

**gAnn** - In this menu you are able to make gamma corrections.

1. Press the MENU button until **gAnn** is displayed, press ENTER.
2. Use the UP or DOWN buttons to gamma corrections.
3. Once you have found your desired dimming frequency press ENTER to confirm.

**di SP** - This function will reverse the display 180°.

1. Press the either the MENU button until **di SP** is displayed, press ENTER.
2. Press the UP button to select “**DSIP**” to “flip” the display, or “**DISP**” to revert the display to normal.
3. Press ENTER to confirm.

**nAnd** - This function will allow you to manually adjust each brightness, fine dimming, and strobing. Fine dimming and strobing are only used with 3 channel mode.

1. Press the MENU button until **nAnd** is displayed, press ENTER.
2. Use the UP and DOWN buttons to scroll through the settings. Once you have found your desired function you would like to adjust press ENTER.
3. After you have pressed ENTER, use the UP and DOWN buttons to adjust the values. Once you have made your adjustments press ENTER to set them. Press the MENU button to exit.

**tEst** - This function will run a self test program.

1. Press the MENU button until **tEst** is displayed, press ENTER.
2. The fixture will now run a self test. Press the MENU button to exit and quit the self test.

**tENP** - With this function you can check the temperature of the fixture.

1. Press the MENU button until **tENP** is displayed, press ENTER.
2. The fixture temperature will now be displayed. Press MENU to exit.

**Fhrs** - With this function you can display the running time of the unit.

1. Press the MENU button until **Fhrs** is displayed, press ENTER.
2. The running time of the fixture will now be displayed. Press MENU to exit.

**vEr** - Use this function to display the Software version of the unit.

1. Press the either the MENU button until **vEr** is displayed, press ENTER.
2. The display will show the software version.

## DMX OPERATION

**Universal DMX Control:** This function allows you to use a universal DMX-512 controller to control the dimmer, fine dimmer and strobe effect. A DMX controller allows you to create unique programs tailored to your individual needs.

1. The Par Z100 5K has 4 DMX channel modes; 1 channel mode, 2 channel mode, 3 channel mode, and 4 channel mode. See page 12 for a detailed description of the DMX values and traits.
2. To control your fixture in DMX mode, follow the set-up procedures on pages 6-7 as well as the set-up specifications that are included with your DMX controller.
3. Use the controller's faders to control the various DMX fixture traits.
4. This will allow you to create your own programs.
5. Follow the instructions on page 9 to select your DMX channel mode and set your desired DMX address.
6. For longer cable runs (more than a 100 feet) use a terminator on the last fixture.
7. For help operating in DMX mode consult the manual included with your DMX controller.

## BEAM ANGLE ADJUSTMENT

To adjust the beam angle slide the beam angle adjuster located inside/in front of the lens. See diagram below.

The beam angle can be adjusted manually, between 9°/ 15°/ 20°/25°/ 30°.

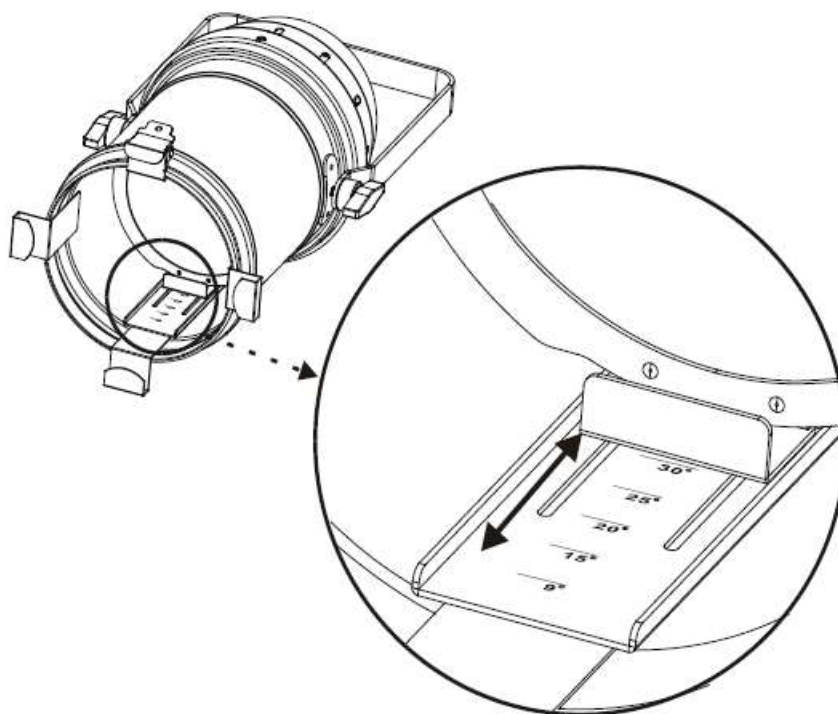

**1 CHANNEL MODE**

Channel	Value	Function
1	0 - 255	DIMMER 0% - 100%

**2 CHANNEL MODE**

Channel	Value	Function
1	0 - 255	DIMMER 0% - 100%
2	0 - 31 32 - 63 64 - 95 96 - 127 128 - 159 160 - 191 192 - 223 224 - 255	Shutter Closed (LEDs OFF) Shutter OPEN (LEDs ON) Strobe effect slow – fast Shutter OPEN (LEDs ON) Pulse effect in sequences Shutter OPEN (LEDs ON) Random strobe effect slow - fast Shutter OPEN (LEDs ON)
		strobing

**3 CHANNEL MODE**

Channel	Value	Function
1	0 - 255	Dimmer 0% - 100%
2	0 - 255	Dimming fine
3	0 - 31 32 - 63 64 - 95 96 - 127 128 - 159 160 - 191 192 - 223 224 - 255	Shutter Closed (LEDs OFF) Shutter OPEN (LEDs ON) Strobe effect slow – fast Shutter OPEN (LEDs ON) Pulse effect in sequences Shutter OPEN (LEDs ON) Random strobe effect slow - fast Shutter OPEN (LEDs ON)
		strobing

**4 CHANNEL MODE**

Channel	Value	Function
1	0 - 255	Dimmer 0% - 100%
2	0 - 255	Dimming fine
3	0 - 31 32 - 63 64 - 95 96 - 127 128 - 159 160 - 191 192 - 223 224 - 255	Shutter Closed (LEDs OFF) Shutter OPEN (LEDs ON) Strobe effect slow – fast Shutter OPEN (LEDs ON) Pulse effect in sequences Shutter OPEN (LEDs ON) Random strobe effect slow - fast Shutter OPEN (LEDs ON)
		strobing
4	0 - 20 21 - 40 41 - 60 61 - 80 81 - 100 101 - 120 121 - 255	Standard Stage Tv Architectural Theatre Stage 2 Default to dimmer curve setting
		Dimmer curves

# DIMMER CURVE CHART

DIMMER

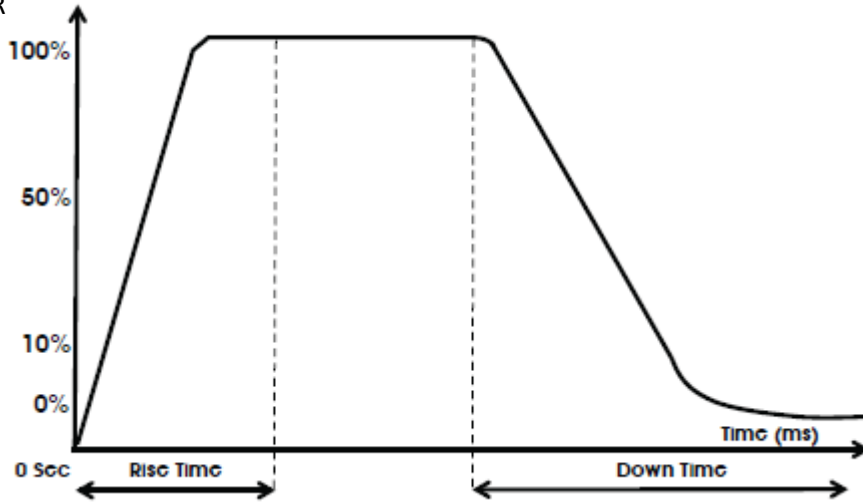

Dimming Curve Ramp Effect	0 sec Fade Time		1 sec Fade Time	
	Rise Time (ms)	Down Time (ms)	Rise Time (ms)	Down Time (ms)
Standard (default)	0	0	0	0
Stage	780	1100	1540	1660
TV	1180	1520	1860	1940
Architectural	1380	1730	2040	2120
Theatre	1580	1940	2230	2280
Stage 2	0	1100	0	1660

# DIMENSIONAL DRAWINGS

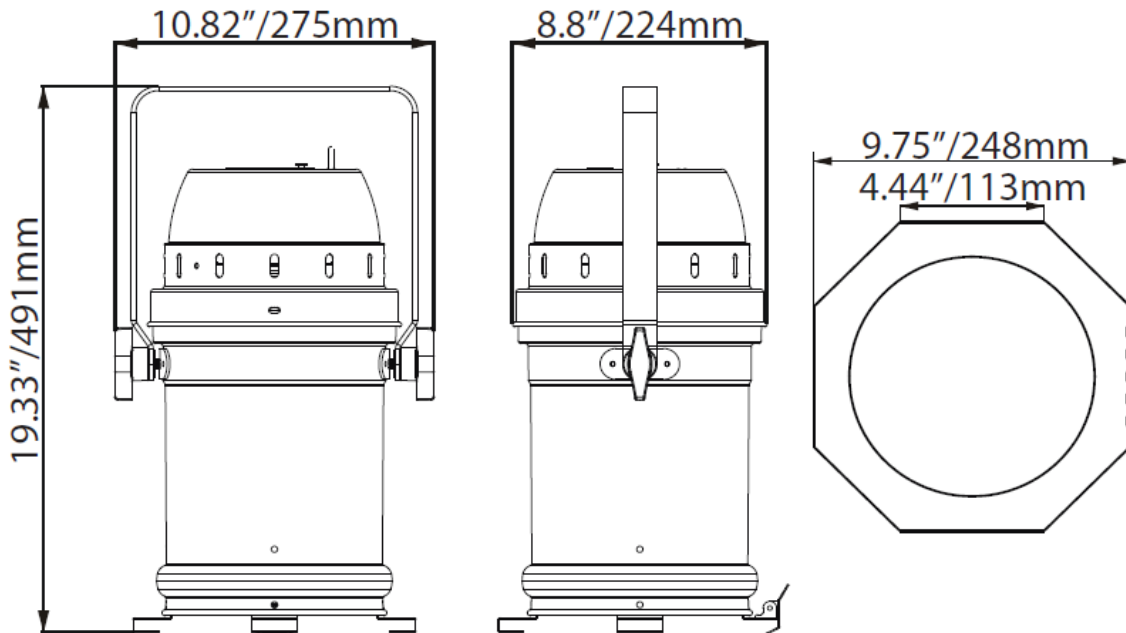

## INSTALLATION

The unit should be mounted using a mounting clamp (not provided), affixing it to the mounting bracket that is provided with the unit. Always ensure that the unit is firmly fixed to avoid vibration and slipping while operating. Always ensure that the structure to which you are attaching the unit is secure and is able to support a weight of 10 times the unit's weight. Also, always use a safety cable that can hold 12 times the weight of the unit when installing the fixture.

The equipment must be installed by a professional, and it must be installed in a place where it is out of the reach of people's grasp.

## MULTIPLE UNIT POWER LINKING

***With this feature you can connect the fixtures to one another using the powerCON input and output sockets. The quantity that can be connected is 15 fixtures maximum @ 120V and 25 fixtures maximum @ 230V. After maximum fixtures is met you will need to use a new power outlet.***

***NOTE: USE CAUTION WHEN POWER LINKING OTHER FIXTURES TO THE PAR Z100 5K AS THE POWER CONSUMPTION OF OTHER LIGHTING FIXTURES WILL VARY!***

## FUSE REPLACEMENT

Unplug the unit from any power source it may be connected to. Once the power has been disconnected, use a Phillips head screw driver to unscrew the fuse holder located above the powerCON input. Remove the bad fuse and replace with a new one, and screw the fuse holder back in.

## CLEANING

Due to fog residue, smoke, and dust cleaning the internal and external optical lenses and mirror should be carried out periodically to optimize light output. Cleaning frequency depends on the environment in which the fixture operates (i.e. smoke, fog residue, dust, dew). In heavy club use we recommend cleaning on a monthly basis. Periodic cleaning will ensure longevity, and crisp output.

1. Use normal glass cleaner and a soft cloth to wipe down the outside casing.
2. Use a brush to wipe down the cooling vents and fan grill.
3. Clean the external optics with glass cleaner and a soft cloth every 20 days.
4. Clean the internal optics with glass cleaner and a soft cloth every 30-60 days.
5. Always be sure to dry all parts completely before plugging the unit back in.

## TROUBLE SHOOTING

***Trouble Shooting:*** Listed below are a few common problems that you may encounter, with solutions.

***No light output from the unit;***

1. Be sure the external fuse has not blown. The fuse is located on the rear panel of the unit.
2. Be sure the fuse holder is completely and properly seated.

<b>Model:</b>	<b>Par Z100 5K</b>
<i>Voltage:</i>	100 - 240V, 50/60Hz
<i>LED:</i>	1 x 98W COB LED
<i>Power Consumption:</i>	115W
<i>Power Linking:</i>	15 Fixtures Max. @ 120V 25 Fixtures Max. @ 230V
<i>Dimensions:</i>	19.33"(L) x 10.82"(W) x 8.75"(H) 491 x 275 x 224mm (with Bracket)
<i>Weight:</i>	8 Lbs. / 3.6 kgs.
<i>Beam Angle:</i>	9/15/20/25/30 Degrees
<i>Fuse:</i>	3.15 Amp
<i>Duty Cycle:</i>	None
<i>DMX:</i>	4 DMX Channel Modes: 1/2/3/4
<i>Color Temperature:</i>	5700K
<i>Working Position:</i>	Any Safe, Secure Position

**Please Note:** Specifications and improvements in the design of this unit and this manual are subject to change without any prior written notice.

**Auto Sensing Voltage:** *This fixture contains an automatic voltage switch, which will auto sense the voltage when it is plugged into the power source.*

Dear Customer,

The European Union has adopted a directive on the restriction / prohibition of the use of hazardous substances. This directive, referred to as ROHS, is a frequently discussed topic in the electronic industry.

It restricts, among other things, six materials: Lead (Pb), Mercury (Hg), hexavalent chromium (CR VI), cadmium (Cd), polybrominated biphenyls as flame retardant (PBB), polybrominated diphenyl, also a flame retardant (PBDE). The directive applies to nearly all electronic and electrical devices whose mode of operation involves electric or electromagnetic fields – in short: each kind of electronics we have around us in our households or at work.

As manufacturers of products of the brands of AMERICAN AUDIO, AMERICAN DJ, ELATION Professional and ACCLAIM Lighting, we are obligated to comply with the RoHS directive. Therefore, as early as two years prior to the directive coming into force, we started our search for alternative environmentally friendly materials and manufacturing processes.

Well before the RoHS directive took effect, all of our products were manufactured meeting the standards of the European Union. With regular audits and material tests we can still assure that the components we use are always RoHS-compliant and that the manufacturing process, as far as the state of technology allows, is environmentally friendly.

The ROHS directive is an important step to the protection of our environment. We, as manufactures, feel obligated to make our contribution in this respect.



## WEEE – Waste of Electrical and Electronic Equipment

Every year thousands of tonnes of electronic components, which are harmful to the environment, end up at the waste disposals around the world. To ensure the best possible disposal or recovery of electronic components, the European Union has adopted the WEEE directive.

The WEEE-system (Waste of Electrical and Electronic Equipment) can be compared with the system of the “Green Spot”, which has been in use for several years. The manufactures have to make their contribution to the utilization of waste at the time they release the product. Money resources obtained by doing so will be applied to develop a common system of waste management. Thereby we can ensure professional and environmentally friendly scraping and recycling program.

As manufactures, we are part of the German system of EAR and we make our contribution towards it.

(Registration in Germany: DE41027552)

That means that products of AMERICAN DJ and AMERICAN AUDIO can be left in the collection points free of charge and they will be used in the recycling program. Products of ELATION Professional, which are used only by professionals, shall be handled by us. Please send Elation products directly to us at the end of their lifetime so that we can professionally dispose of them.

Like the above ROHS, the WEEE directive is an important contribution to the environment protection and we are glad to help to clean the environment with this disposal system.

We are happy to answer any of your inquiries and welcome your suggestions at: [info@americandj.eu](mailto:info@americandj.eu)

ADJ Products, LLC  
6122 S. Eastern Ave. Los Angeles, CA 90040 USA  
Tel: 323-582-2650 / Fax: 323-725-6100  
Web: [www.adj.com](http://www.adj.com) / E-mail: [info@americandj.com](mailto:info@americandj.com)

Follow Us On:



[facebook.com/americandj](https://facebook.com/americandj)  
[twitter.com/americandj](https://twitter.com/americandj)  
[youtube.com/americandj](https://youtube.com/americandj)

A.D.J. Supply Europe B.V.  
Junostraat 2  
6468 EW Kerkrade  
The Netherlands  
Tel: +31 45 546 85 00 / Fax: +31 45 546 85 99  
Web: [www.adj.eu/](http://www.adj.eu/) E-mail: [support@adj.eu](mailto:support@adj.eu)